

# Safer, higher quality Elastomer products

## Modeling and analysis solutions

Elastomers are used extensively in all major industries for their flexibility, resilience and customizable properties for sealing, vibration damping, and electric and thermal insulation. Their ability to bond with other materials makes them good candidates for designs with reinforcements, delivering increased strength and load bearing capability.

Because of their complex behavior, it is critical that engineers understand their response under the entire service load spectrum well before releasing a product in the market. This is increasingly accomplished through simulation, which has made strides in modeling the elastomer behavior accurately. Aided by robust and industry-proven simulation technology, MSC Software is in the forefront of solving elastomer analysis problems. This document provides a brief overview of some of the most common design problems with elastomers and the solutions that help engineers achieve their design goals in a cost-effective manner.

### Model large strain, large deformation behavior

Reliable analysis of rubber components like seals, tires, and mounts, requires special material models capable of representing their complex behavior at large strains accurately. Engineers take advantage of the following proven capabilities to address their problems.

- Model nonlinear stress-strain behavior with industry-tested material formulations like General-ized Mooney-Rivlin, Ogden, Gent, Arruda-Boyce, Marlow, and user defined material models.
- Close the gap between testing and simulation through integrated curve fitting capability to determine material coefficients for elastomers
- Use the robust element formulations designed and tested for optimal performance in nonlinear domain
- Capture the deformation behavior of parts undergoing large distortions with Marc's adaptive 2-D and 3-D remeshing technology.

### Analyze wrinkling and buckling

Elastomers often experience buckling under the compression loads, and it is critical to capture this behavior to help engineers address issues like seal leakage, and insufficient sealing pressure.

- Solve the difficult wrinkling problems with elements that are formulated to perform well under large deformations
- Save modeling time with intuitive and easy-to-setup contact capability to model multiple com-ponents interacting with each other

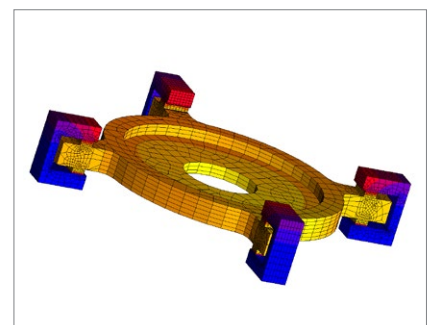
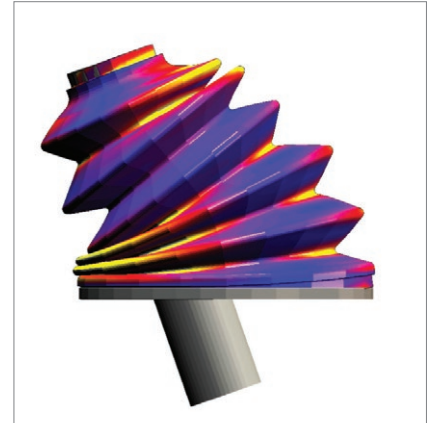

- Obtain robust solution with automatic detection of self-contact to model folding of rubber parts

### Simulate orthotropic response of rubber parts

Elastomers are highly customizable, and components like belts are designed to have orthotropic properties to handle directional loads effectively. Marc enables you to model the non-isotropic behavior of this class of complex materials.

- Choose from three anisotropic hyperelastic material models (Qiu and Pence, Brown and Smith, Gasser, Ogden and Holzapfel) to model the direction-dependent behavior of elastomers
- Study the influence of reinforcements on flexibility and strength of products like hoses and belts.
- Understand natural behavior of biological materials like muscle and arterial layers with distributed collagen fiber orientations

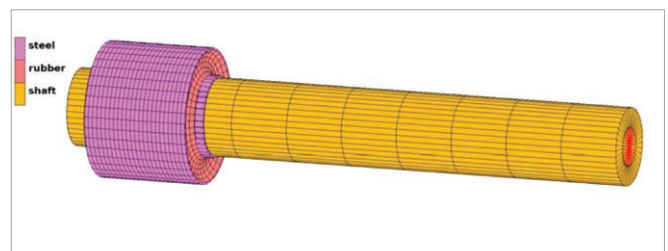
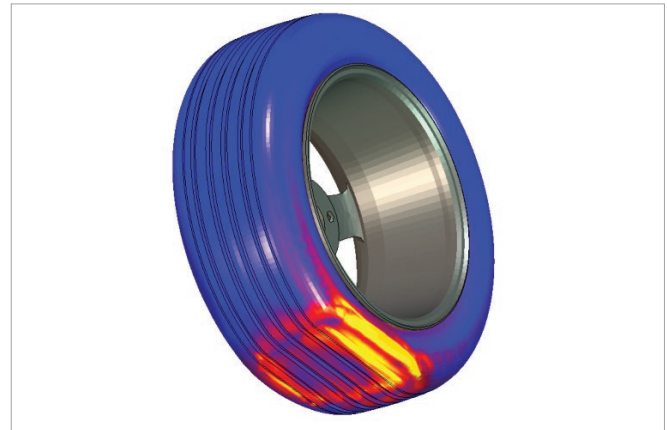

### Simulate time dependent response

Rubbers undergo deformations that involve both nonlinear time-independent and time-dependent stress-strain behaviors. Analysis of time-dependent behavior is important in applications where the parts undergo transient loads.

- Use Bergström-Boyce model to accurately model the time-dependent large strain viscoelastic behavior of hyperelastic materials
- Simulate the permanent set in elastomers to achieve better sealing and product life

### Create safer products by understanding rubber failure

The molecular chains in an elastomer can experience damage even at small strains. The damage accumulation depends on temperature, loading history and the constituents of the materials.

- Analyze continuous and discontinuous damage accumulation in elastomers
- Obtain required parameters with curve fitting
- Implement custom damage models with user subroutines



**Nonlinear analysis with Marc helps us dramatically improve the design of CV boots and other products. Our simulation capabilities enable us to design boots that substantially outlast competitive designs.”**

**Richard Kennison,**  
Sr. Design Engineer, Race-Tec

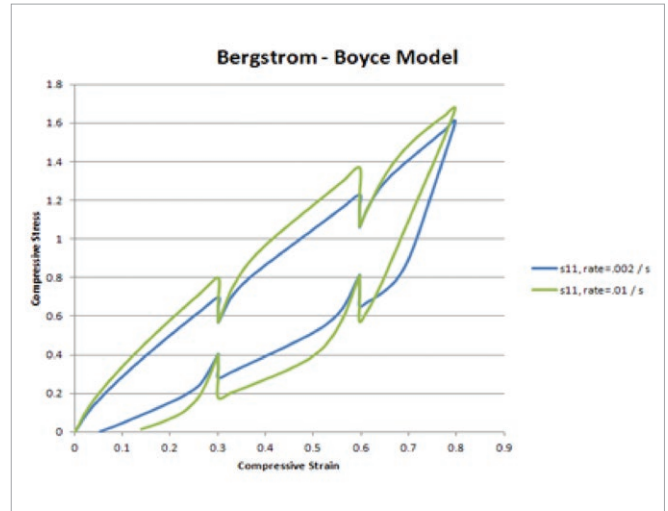
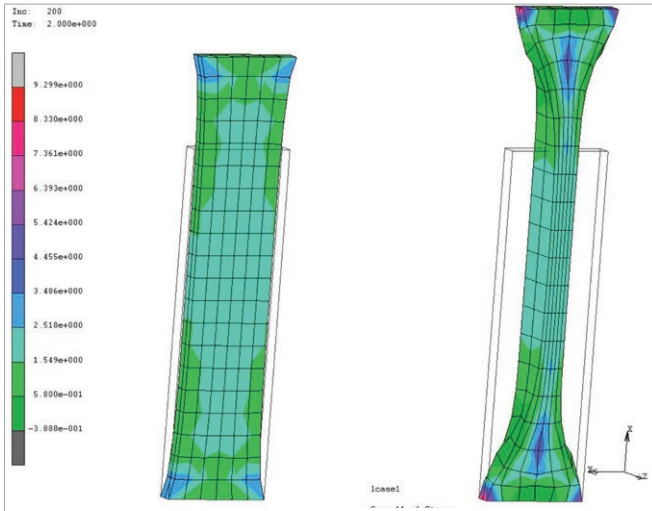

### Dampen vibrations and improve isolation

Dynamic excitation is often applied to rubber components like engine mount and bearings, whose role is to isolate and dampen these vibrations over a particular frequency range.

- Model material response under dynamic loading in frequency domain
- Analyze materials with damping that is dependent on frequency and amplitude
- Study the effects of pre-deformation/pre-stress on the frequency response of elastomers

### About Marc

Marc is a powerful, general-purpose, nonlinear finite element analysis solution to accurately simulate the response of your products under static, dynamic and multi-physics loading scenarios. Marc enables you to simulate complex real world behavior of mechanical systems making it best suited to address your manufacturing and design problems in a single modeling environment.





Hexagon is a global leader in sensor, software and autonomous solutions. We are putting data to work to boost efficiency, productivity, and quality across industrial, manufacturing, infrastructure, safety, and mobility applications.

Our technologies are shaping urban and production ecosystems to become increasingly connected and autonomous – ensuring a scalable, sustainable future.

MSC Software, part of Hexagon's Manufacturing Intelligence division, is one of the ten original software companies and a global leader in helping product manufacturers to advance their engineering methods with simulation software and services. Learn more at [mscsoftware.com](https://www.mscsoftware.com). Hexagon's Manufacturing Intelligence division provides solutions that utilise data from design and engineering, production and metrology to make manufacturing smarter.

Learn more about Hexagon (Nasdaq Stockholm: HEXA B) at [hexagon.com](https://www.hexagon.com) and follow us [@HexagonAB](https://twitter.com/HexagonAB).